

RELAY REMOTE CONTROL
RCR-ML

REMOTE CONTROL RECEIVER MODULE

PRELIMINARY

DATA SHEET

Radios, Inc.

May 4, 2007 Preliminary Data Sheet

Radios, Inc.

RCR-ML

REMOTE CONTROL RECEIVER MODULE

The RCR-ML is a versatile, high performance, long range receiver for remote control wireless applications. The remote control is designed for use with all 8 of the 18-pin MRX Micrel RF receiver modules, ranging from 315-916.5 MHz. It can be configured to use a Holtek, Keeloq, or proprietary decoder. It is available with 1, 2, or 3 relays on the board with corresponding quick interface relay terminals. A data header also provides easy access to the data received from the RF receiver module. The remote control

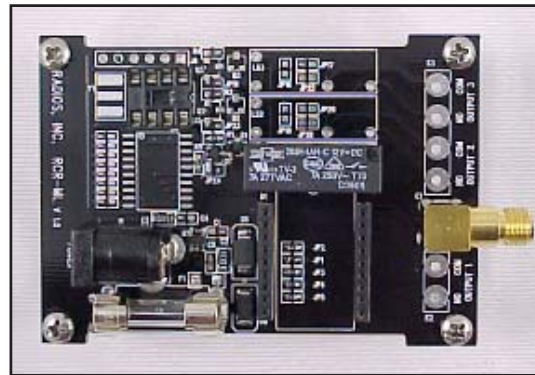

receiver allows a variety of antenna options for an SMA connector. Power is supplied through either a convenient wall-mount adapter or pig-tail connectors with an on-board fuse. Mounting can be done via the four 1/8" diameter mounting holes in each corner of the board. The RCR-ML operates at low power consumption, generates low harmonic emissions and is a highly reliable wireless link.

Typical Applications:

- Remote controls
- Garage openers / Gate controls
- Keyless entry
- Lighting control
- Periodic data transfer
- Remote access
- Guard patrol / Lone worker protection
- Domestic / Commercial security
- Fire / Security alarms
- General wire elimination

Key Features

- Low cost
- Commonly employed RKE frequencies
- Wide operating temperature range
- Low power consumption
- Small size
- No production tuning

Contact Information

Radios, Inc.
1408 Center Avenue
Oostburg, WI 53070

Phone: 920-564-6622
Fax: 920-564-6630
Email: sales@radiosinc.com

RCR-ML

REMOTE CONTROL RECEIVER MODULE

Mechanical and Pin Diagram

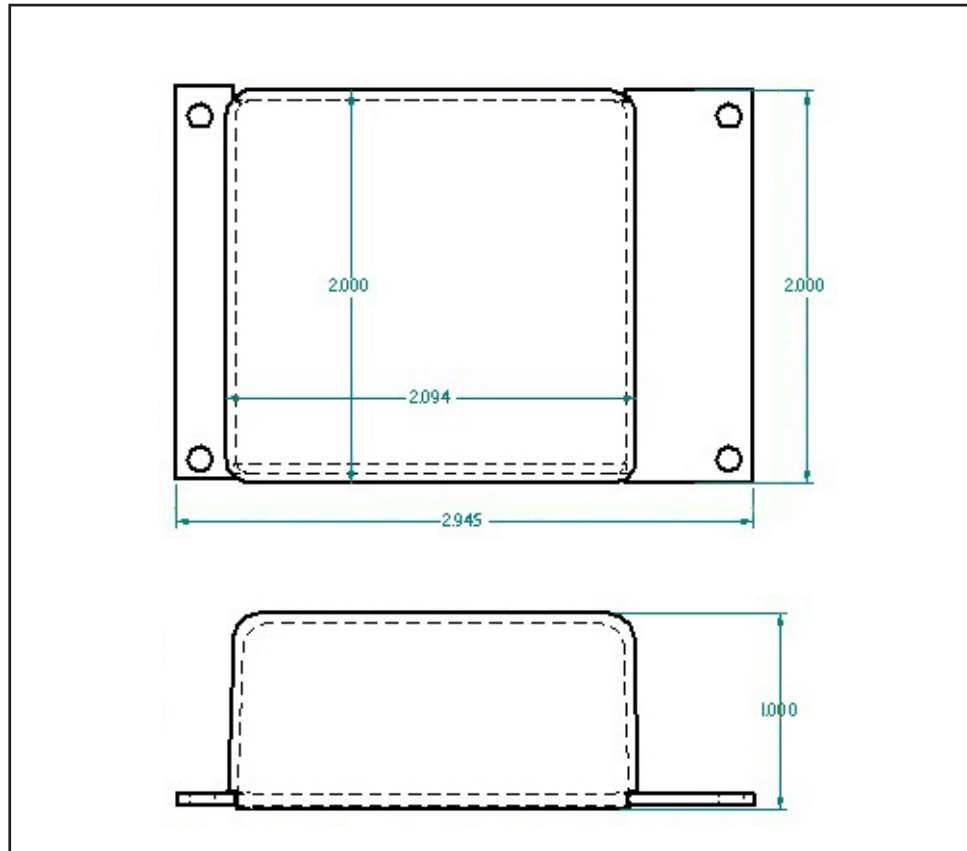

Pin Description

Pin Num	Pin Name	Description	Pin Num	Pin Name	Description
Pin 1	+5V	5 Volt Supply Pin	OUT1	OUTPUT1	Relay 1 - NO
Pin 2	I/O	General Purpose I/O	OUT2	OUTPUT2	Relay 1 - COM
Pin 3	I/O	General Purpose I/O	OUT3	OUTPUT3	Relay 2 - NO
Pin 4	GND	Ground	OUT4	OUTPUT4	Relay 2 - COM
Pin 5	RXDATA	Received Data	OUT5	OUTPUT5	Relay 3 - NO
Pin 6	DECOUT	Decoder Output	OUT6	OUTPUT6	Relay 3 - COM
PWR	POWER JACK/LEADS	9V Input with 9V relay 12V Input with 12V relay 24V Input with 24V relay			

RCR-ML

REMOTE CONTROL RECEIVER MODULE

Electrical Limits

Sym	Parameters	Min	Typ	Max	Unit	Notes
Absolute Maximum Ratings						
VDDRF, VDDBB	Supply Voltage	Voltage Dependent			V	
	Storage Temperature Range	-65		150	°C	

Electrical Characteristics

This device is ESD sensitive. Do not operate or store near strong electrostatic fields. Use appropriate ESD precautions. All voltages are with respect to Ground.

Parameters	Test Conditions	Min	Typ	Max	Unit
Power Supply					
Operating Current with 9V relay (note 3)	1 relay activated		TBD		mA
	2 relays activated		TBD		mA
	3 relays activated		TBD		mA
Operating Current with 12V relay (note 3)	1 relay activated		34		mA
	2 relays activated		60		mA
	3 relays activated		85		mA
Operating Current with 24V relay (note 3)	1 relay activated		TBD		mA
	2 relays activated		TBD		mA
	3 relays activated		TBD		mA
Quiescent Current	with relays off		5.6		mA
RF/IF Section					
See individual receiver's data sheet for RF/IF characteristics					

Note 1: Exceeding the absolute maximum ratings may damage the device.

Note 2: The device is not guaranteed to function outside its operating ratings.

Note 3: Testing conducted with MRX-010 receiver module

RCR-ML

REMOTE CONTROL RECEIVER MODULE

Technical Support:

Radios, Inc. is committed to providing its customers with excellent technical support and the resources necessary to assist them with their product development. All technical support is provided free of charge. Customers have several options to obtain assistance. First, any questions or concerns can be e-mailed to Radios, Inc. at information@radiosinc.com. We monitor our e-mail daily, and will respond to all questions promptly. Additionally, to speak directly to a technical support representative, customers can call Radios, Inc. at 920-564-6622.

Compliance:

Embedded wireless modules are intended for use as component devices which require peripheral elements to operate. Radios, Inc.'s modules are intended to be used in products requiring compliance. They are, however, not pre-approved by the FCC or any other agency worldwide unless so stated. The user or customer understands that regulatory compliance may be required prior to the sale or operation of the module or development system, and agrees to abide by all laws governing the module's or development system's use in the country of operation.

The approval process of embedded wireless modules in the United States is relatively uncomplicated. The Federal Communications Commission (FCC) is the governing body in the US that specifies its requirements in the Code of Federal Regulations (CFR), Title 47. Title 47 consists of several volumes and it is necessary to first identify the correct section that applies to your application. These rules require that a device which intentionally creates RF emissions be FCC compliant; i.e., pre-tested for compliance and assigned an identification number. Radios, Inc. offers pre-screening at one of our affiliate test sites. Final certification is then accomplished by an independent test laboratory. After passing compliance testing, you will be issued a unique ID number which must be placed on each product manufactured.

Any questions dealing with interpretations of the rules relating to testing or compliance should be addressed to:

FCC
Equipment Authorization Division
Customer Service Branch, MN 1300F2
7435 Oakland Mills Road
Columbia, MD 21046

RCR-ML

REMOTE CONTROL RECEIVER MODULE

Returns:

Products may be returned directly to Radios, Inc. for evaluation. Returns, without exception, must have a valid RMA number attached. RMA numbers can be obtained by calling a customer service representative at Radios, Inc. If a product is found to be defective and is returned within 90 days of purchase, Radios, Inc. may repair or replace, at its option, said defective product. The warranty does not apply to any products which have been disassembled, modified or subjected to conditions exceeding the application specifications. Under no circumstances will Radios, Inc. be responsible for losses, financial or other, arising from the use or failure of a device in an application or for losses arising from failure to meet delivery requirements, other than the repair, replacement, or refund limited to the original product purchase price. No other warranties, express, implied, or statutory, including warranty of fitness for a particular purpose, apply.

Product Warranty and Disclaimer Information:

Radios, Inc. is dedicated to providing its customers with the best possible products, and is continually working on improving the quality and function of its entire product line. Therefore, Radios, Inc. reserves the right to make changes to the design, specifications, or manufacturing of its products without notice. The information contained in this data sheet is believed to be complete, accurate, and reliable as of the time of publication. Because product specifications are based on representative lot samples, however, values can vary from lot to lot and are not guaranteed. Radios, Inc. does not assume any liability or responsibility arising from the application or use of any product described herein, and makes no guarantee, warranty, or representation regarding the suitability or legality of any product for use in a specific application. Radios, Inc. does not assume any liability for any infringement of patents or other rights of third parties which may result from the use of its products. No product sold by Radios, Inc. is intended for use in a life critical application, or any application where the safety of property is at risk. The user assumes full and complete responsibility for any use of Radios, Inc.'s products in an application where the safety of life or property is at stake.

Radios, Inc., its suppliers, and its licensors shall in no event be liable for any damages arising from the use of or inability to use this product. This includes business interruption, loss of business information, or other losses that may arise from the use of this product. Some devices described in this publication are patented. Under no circumstances shall any user be conveyed any license or right to the use or ownership of these patents.

Copyright:

Radios Inc. reserves the right to all proprietary or commercial information contained in this data sheet. This data sheet is protected by copyright, and any unauthorized copying, reproduction, or dissemination is strictly prohibited without the prior written approval of Radios Inc.

RCR-ML

REMOTE CONTROL RECEIVER MODULE

Editorial Information:

Last Updated (Date)
May 4, 2007 PRELIMINARY

Product Ordering Information:

RCR-ML 9 - 009 RI - RF J 1 SV - PT

Interface:	PT - Pig-tail - Terminal Block
Switch Type:	SV - Switched Voltage FS - FET Switch - Relay
Contacts:	1 2 3
Power:	J - Jack - Leaded
Fuse Type:	- Fixed Fuse: Customer Specified * (Jumpered as default) RF - Replaceable Fuse
Decoder:	RI - Radios, Inc. Code KL - Keeloq HT - Holtek ST - Socket
Receiver:	001 = MRX-001 002 = MRX-002 005 = MRX-005 007 = MRX-007 008 = MRX-008 009 = MRX-009 010 = MRX-010 011 = MRX-011
Voltage:	9 - +9 Volt 12 - +12 Volt 24 - +24 Volt